

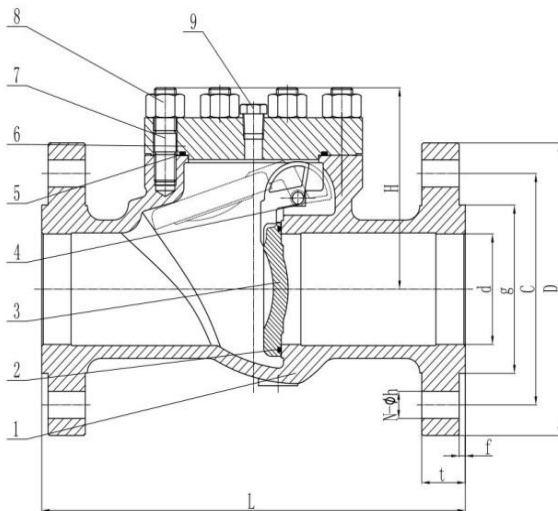

TOP OILFIELD PRODUCTS

FLANGED END CHECK VALVE

TFKA CLASS 300 SERIES



Features:

- WCB Cast Body and Adapter
- Integral or replaceable seat available
 - Valves Designed to API6D ASME B16.34 standard
- Valves Flanges ASME B16.5 standard
- 316SS disc standard
- Bolted bonnet with tap is standard
- NACE MR0175
- 6 inserted pin spring type

Specifications

NOMINAL PRESSURE	740psi	5.1Mpa
SHELL STRENGTH (WATER)	1125psi	7.8Mpa
SEALING TEST (WATER)	815psi	5.8Mpa
SEALING TEST (AIR)	80.8psi	0.55Mpa

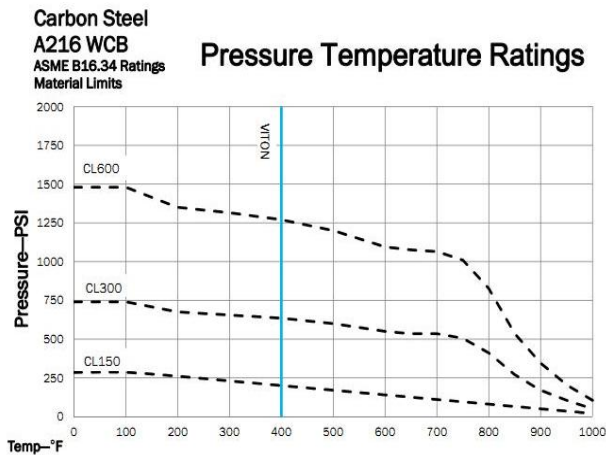

Parts & Materials

NO.	Description	Material
1	BODY	ASTM A216 WCB
2	SEAT	VITON
3	DISC	ASTM A351 CF8M
4	DISC SEAT	SS316
5	BONNET SEAL	VITON
6	BONNET	ASTM A216 WCB
7	STUD	ASTM A193 B7
8	NUT	ASTM A194 2H
9	BONNET SCREW	CARBON STEEL

Dimensions(in)

NPS	L	D	C	g	d	N	h	t	f	H
2"	10.50	6.50	5.00	3.62	2.06	8	0.75	0.88	0.06	4.65
3"	12.50	8.27	6.63	5.00	3.13	8	0.88	1.13	0.06	5.81
4"	14.00	10.00	7.87	6.18	4.06	8	0.88	1.25	0.06	6.69
6"	17.50	12.50	10.63	8.50	5.91	12	0.88	1.44	0.06	7.87

Address: 9239 Alberene Dr. Houston Texas 77074
Tel: 832-480-3855, e-mail: sales@topoilfieldproducts.com